

DATA SHEET

Specifications & Performance

Certified Quality



Quality System
ISO 9001 Certified



Environmental Management System
ISO 14001 Certified



Certified to CSA Technical Letter No. R-14



Certified to ANSI LC6-2008



Warren Rupp, Inc.
A Unit of IDEX Corporation
800 N. Main St.,
Mansfield, Ohio 44902 USA
Telephone 419.524.8388
Fax 419.522.7867
SANDPIPERPUMP.COM



© Copyright 2016 Warren Rupp, Inc.
All rights reserved

Model G20F

Metallic Flap Valve

Design Level 1

Natural Gas-Operated

Diaphragm Pumps

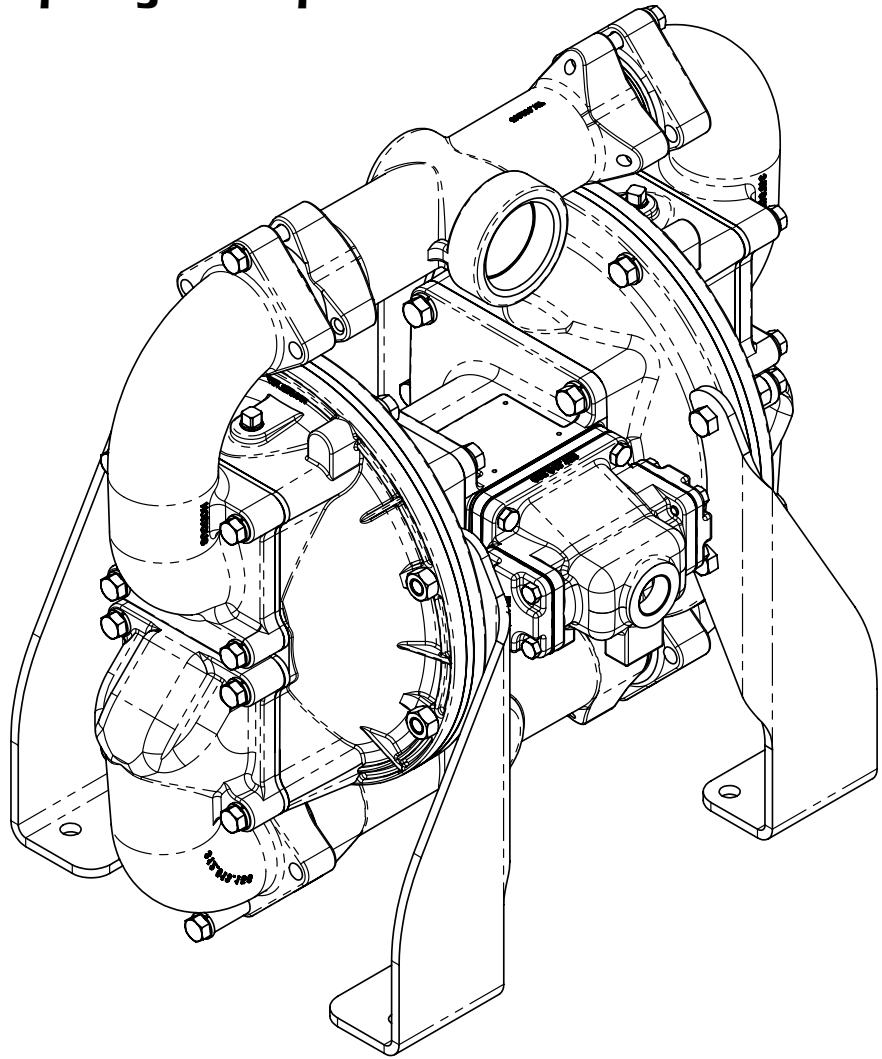

SANDPIPER[®]
A WARREN RUPP, INC. BRAND

SANDPIPERPUMP.COM

Explanation of Pump Nomenclature

Your Model #: **G**

(fill in from pump nameplate)

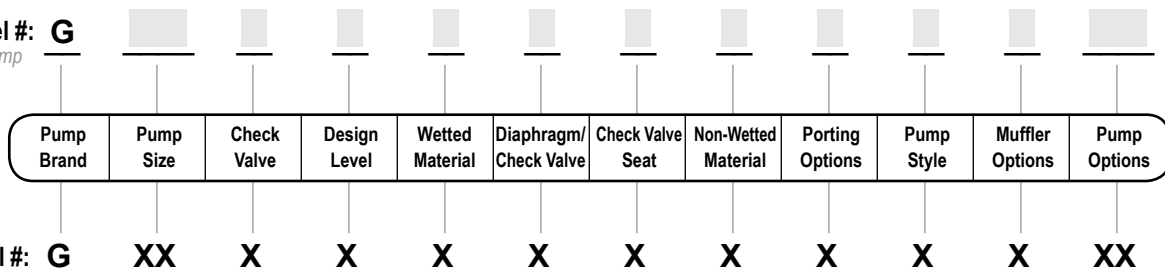

Pump Brand

G Gas Operated

Pump Size

20 2"

Check Valve Type

F Flap

Design Level

1 Design Level

Wetted Material

S Painted Stainless Steel

A Painted Aluminum

Diaphragm/Check Valve Materials

B Nitrile/Nitrile

V FKM/FKM

Check Valve Seat

S Stainless Steel

Non-Wetted Material Options

A Painted Aluminum with Nitrile Elastomer Parts

V Painted Aluminum with FKM Elastomer Parts

Porting Options

N NPT Threads

Pump Style

S Standard

Muffler Options

X No Muffler Permitted *

Your Serial #: (fill in from pump nameplate) _____

ATEX Detail



II 2G c T5

II 2D c T100°C

Performance

G20F NATURAL GAS-OPERATED

SUCTION/DISCHARGE PORT SIZE

- 2"

CAPACITY

- 0 to 140 gallons per minute
(0 to 530 liters per minute)

GAS DISTRIBUTION VALVE

- No-lube, no-stall design

SOLIDS-HANDLING

- Up to 2 in. (50mm)

HEADS UP TO

- 100 psi or 231 ft. of water
(7 bar or 70 meters)

MAXIMUM OPERATING PRESSURE

- 100 psi (7 bar)

DISPLACEMENT/STROKE

- .42 Gallon / 1.59 liter

SHIPPING WEIGHT

- Aluminum 69 lbs. (31kg)
- Stainless Steel 114 lbs. (52kg)

These pump models are designed to pump the following fluids:
Crude Oil, Salt Water, Drilling Mud, Condensate, Lubrication Oils,
Glycol, Caustic Liquids, and Acids."

MODEL G20F Performance Curve

Performance based on the following: elastomer fitted pump, flooded suction, water at ambient conditions.
The use of other materials and varying hydraulic conditions may result in deviations in excess of 5%.

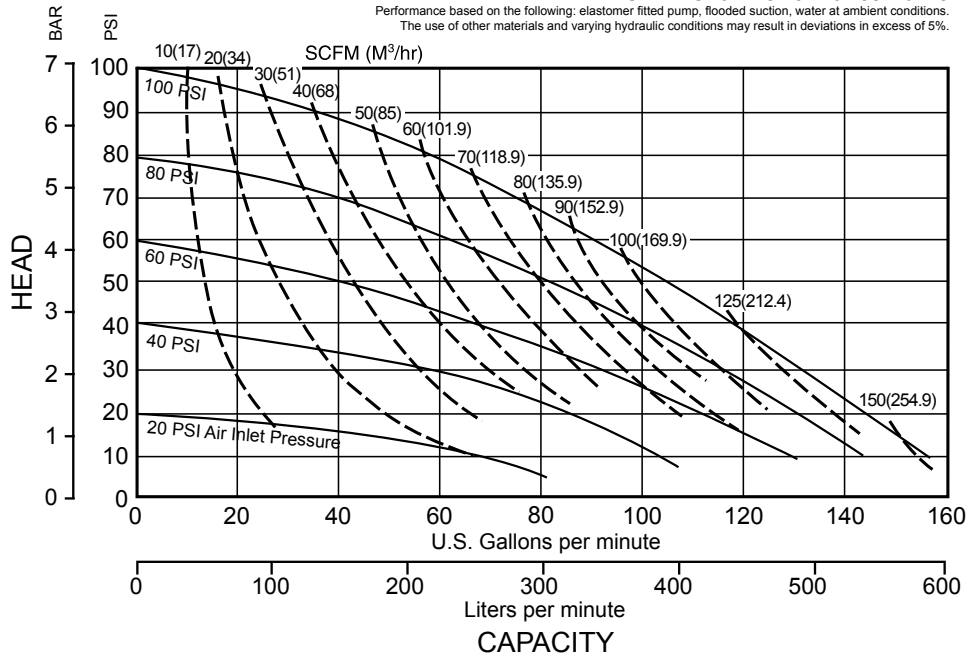

Exhaust Gas: The exhausted natural gas must be vented to a low pressure safe location in accordance with local fire safety and environmental codes, or in the absence of local codes, an industry or nationally recognized code having jurisdiction over the specific installations, and/or CAN/CGA B149, Installation Codes

Materials

Material Profile:

CAUTION! Operating temperature limitations are as follows:

FKM: (Fluorocarbon) Shows good resistance to a wide range of oils and solvents; especially all aliphatic, aromatic and halogenated hydrocarbons, acids, animal and vegetable oils. Hot water or hot aqueous solutions (over 70°F(21°C)) will attack FKM.

Nitrile: General purpose, oil-resistant. Shows good solvent, oil, water and hydraulic fluid resistance. Should not be used with highly polar solvents like acetone and MEK, ozone, chlorinated hydrocarbons and nitro hydrocarbons.

Maximum and Minimum Temperatures are the limits for which these materials can be operated. Temperatures coupled with pressure affect the longevity of diaphragm pump components. Maximum life should not be expected at the extreme limits of the temperature ranges.

Metals:

Stainless Steel: Equal to or exceeding ASTM specification A743 CF-8M for corrosion resistant iron chromium, iron chromium nickel and nickel based alloy castings for general applications. Commonly referred to as 316 Stainless Steel in the pump industry.

For specific applications, always consult the Chemical Resistance Chart.

Ambient temperature range: -20°C to +40°C

Process temperature range: -20°C to +100°C for models rated as category 2 equipment

In addition, the ambient temperature range and the process temperature range do not exceed the operating temperature range of the applied non-metallic parts as listed in the manuals of the pumps.

Dimensional Drawings

G20F Metallic

Dimensions in inches (mm dimensions in brackets). Dimensional Tolerance: $\pm 1/8"$ ($\pm 3\text{mm}$)

The dimensions on this drawing are for reference only. A certified drawing can be requested if physical dimensions are needed.

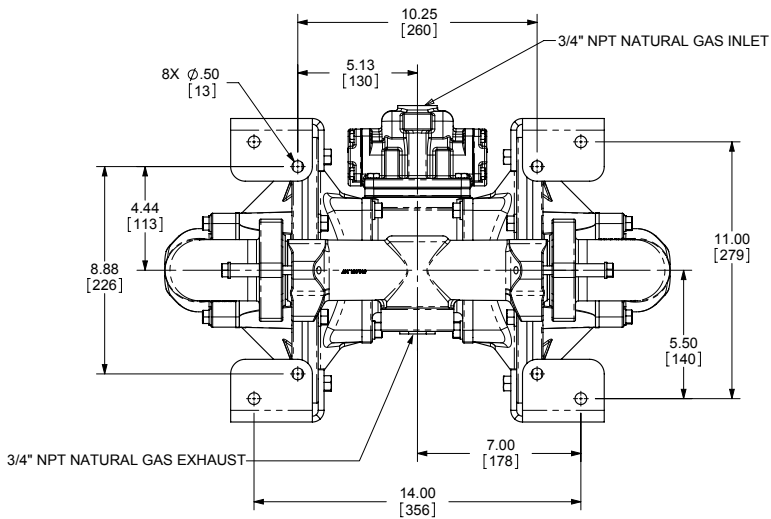
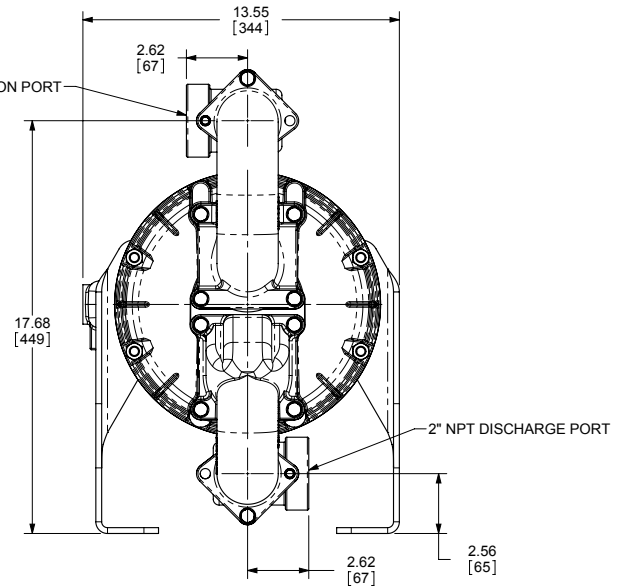
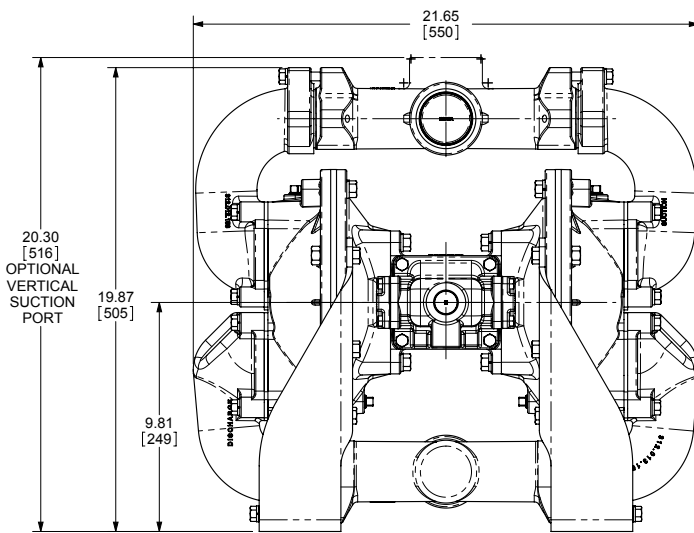

5 - YEAR Limited Product Warranty

Warren Rupp, Inc. ("Warren Rupp") warrants to the original end-use purchaser that no product sold by Warren Rupp that bears a Warren Rupp brand shall fail under normal use and service due to a defect in material or workmanship within five years from the date of shipment from Warren Rupp's factory. Warren Rupp brands include Warren Rupp®, SANDPIPER®, MARATHON®, PortaPump®, SludgeMaster™ and Tranquilizer®.

~ See sandpiperpump.com/content/warranty-certifications for complete warranty, including terms and conditions, limitations and exclusions. ~

**WARREN
RUPP, INC.**

Declaration of Conformity

Manufacturer: Warren Rupp, Inc., 800 N. Main Street
Mansfield, Ohio, 44902 USA

Certifies that Air-Operated Double Diaphragm Pump Series: HDB, HDF, M Non-Metallic, S Non-Metallic, M Metallic, S Metallic, T Series, G Series, U Series, EH and SH High Pressure, RS Series, W Series, SMA and SPA Submersibles, and Tranquilizer® Surge Suppressors comply with the European Community Directive 2006/42/EC on Machinery, according to Annex VIII. This product has used Harmonized Standard EN809:1998+A1:2009, Pumps and Pump Units for Liquids - Common Safety Requirements, to verify conformance.

David Roseberry
Signature of authorized person

David Roseberry
Printed name of authorized person

Revision Level: F

October 20, 2005
Date of issue

Engineering Manager
Title

August 23, 2012
Date of revision

IBEX

CE

WARREN RUPP, INC.

EC / EU Declaration of Conformity

The objective of the declaration described is in conformity with the relevant Union harmonisation legislation: Directive 94/9/EC (until April 19, 2016) and Directive 2014/34/EU (from April 20, 2016).

Manufacturer:

Warren Rupp, Inc.
A Unit of IDEX Corporation
800 North Main Street
P.O. Box 1568
Mansfield, OH 44902 USA

Applicable Standard:

EN13463-1: 2001
EN13463-5: 2003
EN60079-25: 2004

Harmonised Standard:

EN13463-1: 2009
EN13463-5: 2011
EN60079-25:2010

The harmonised standards have been compared to the applicable standards used for certification purposes and no changes in the state of the art technical knowledge apply to the listed equipment.

AODD Pumps and Surge Suppressors

Technical File No.: 203104000-1410/MER

AODD (Air-Operated Double Diaphragm) Pumps

EC Type Examination Certificate No. Pumps: KEMA 09ATEX0071 X

DEKRA Certification B.V. (0344)
Meander 1051
6825 MJ Arnhem
The Netherlands

Hazardous Locations Applied:

I M1 c	II 1 G c T5
II 2 G Ex ia c II CT5	II 1 D c T100°C
II 2 D Ex c iaD 20 IP67 T100°C	II 2 G c T5
II 2 G Eex m c II T5	II 2 D c T100°C
II 2 D c IP65 T100°C	

SANDPIPER[®]
A WARREN RUPP, INC. BRAND

Tranquilizer[®]

DATE/APPROVAL/TITLE:
18 March 2016

David Roseberry
David Roseberry, Director of Engineering

IDEX